

FABRIC EXPANSION JOINTS & SLEEVE COVERS

CONTACT INFORMATION

Date _____ Address _____
 Quantity _____ City _____
 Company Name _____ State/Province _____
 Contact _____ Country _____
 Ph _____ Zip/Postal Code _____
 Fx _____
 Email _____

We offer sewn bellows construction combined with a wide variety of materials to optimize your design. These boots will provide complete protection through the machine's full range of motion.

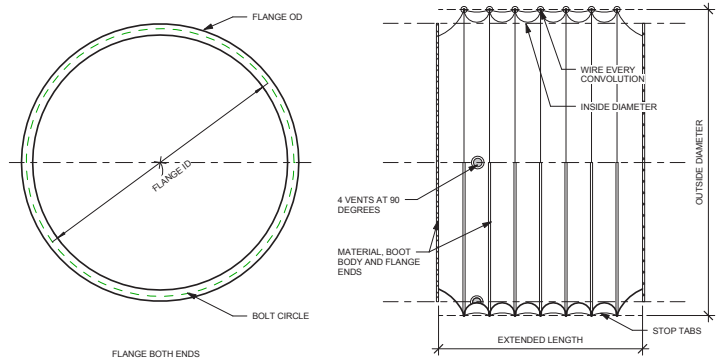
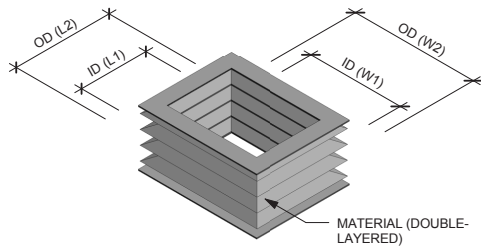

SPECIFICATIONS

OVERALL LENGTH (A) _____

LENGTH TO BELLOW (B) _____

RADIUS OF BELLOW (R) _____

MATERIAL _____

CONNECTION TYPE:

COLLAR

FLANGE

LENGTH _____

ID _____

OD _____

ID _____

BC _____

HOLE DIA. _____

OF HOLES _____

